

# CRETEX EXTERNAL X-85 SEAL

External Frame/Chimney Seal.



## ADVANTAGES:

- Less expensive alternative to our proven heavy weight external chimney seal.
- Easy installation.
- No primers required.
- No torches required.
- No special tools needed.
- Simple readjustment to accommodate grade changes.
- Provides permanent, flexible, watertight seal.
- Can span 12" of adjustment without extension.
- Can accommodate offsets and diameter differential.
- Can be used for both above or below grade applications.

**CRETEX EXTERNAL X-85 SEAL** is a high-performance watertight seal for use between the manhole casting and concrete cone. Our state-of-the-art technology combines all of the advantages of a mechanical seal in a more economical version that is easy to use.

**HOW DOES IT WORK?** The top band of the seal is designed to add compression to the inner rubber sealing fins, uniformly filling the annular space between the frame and the cone. The resulting seal forms a watertight barrier around the top, bottom and outer edges of the frame's base flange.



Our unique "C"-shape band mechanically locks the seal on the manhole casting for lasting performance. Our high-performance seal requires no primers torches or special tools to create a watertight barrier.



The securing band adds additional compression to the sealing fins, instantly filling any minor voids or irregularities.

# SPECIFICATIONS

## SUGGESTED CONDENSED EXTERNAL MANHOLE FRAME SEAL SPECIFICATION

(New Construction X-85 Lightweight External Seal)

### PART 1 GENERAL

#### 1.01 WORK REQUIRED

The Contractor shall install a frame seal on all new sanitary manholes included in this project. The frame seal shall span the entire grade adjustment area of the manhole by connecting to the bottom base flange of the manhole frame casting and to the top of the manhole cone.

#### 1.02 SUBMITTALS

The Contractor shall make submittals of the Manufacturers literature, shop drawings installation instructions and other items in accordance with the provisions of the Standard Specifications..

### PART 2 PRODUCTS

#### 2.01 FRAME SEAL

The frame seal shall remain flexible throughout a 25 year design life, allowing for repeated vertical movement of the frame of not less than 2 inches and/or repeated horizontal movement of not less than 1/2 inch. The sleeve portion of the seal shall be corrugated with a minimum unexpanded vertical height of 10 inches and be capable of being mechanically locked to the base flange of the manhole frame casting. The sleeve and any extension shall have a minimum thickness of 0.085 inches and shall be made from a high quality EPDM rubber suitable for both above and below grade applications. The rubber shall conform to the applicable material requirements of ASTM C-923 and have a hardness (durometer) of 45+5. The area of the seal that compresses against the base flange of the manhole frame casting and the chimney/cone shall have a series of sealing fins to facilitate a watertight seal.

The top compression band shall be "C" shaped to uniformly compress and mechanically lock the sleeve onto the base flange of the manhole frame casting. Both the top and bottom compression bands shall have a take-up mechanism capable of developing a minimum of 400 lbs. of torque.

- A. Acceptable Manufacturers
  - 1. Cretex Specialty Products

### PART 3 EXECUTION

#### 3.01 SURFACE PREPARATION AND INSTALLATION

The surface preparation and installation of the frame seal shall be in accordance with the manufacturer's instructions.

### PART 4 MEASUREMENT AND PAYMENT

#### 4.01 FRAME SEAL AND EXTENSIONS

All costs for furnishing and installing an external frame seal shall be included in the unit price bid for sanitary manholes.

**NOTE:** A specifier is within his rights to issue a proprietary specification that names only one brand. If in the informed and professional judgment of the specifier, his client's needs will be best served by naming a particular brand, then he has the responsibility to limit his specification to one source. This practice is even acceptable on publicly funded projects. This principle of proprietary specification has found legal support in the case of Whitten Corp v. Paddock Pool Builders, Inc., a Federal District Court case from Massachusetts (376 F. Supp125). Further support came in 1975 when the U.S. Supreme Court rejected further appeal and review.

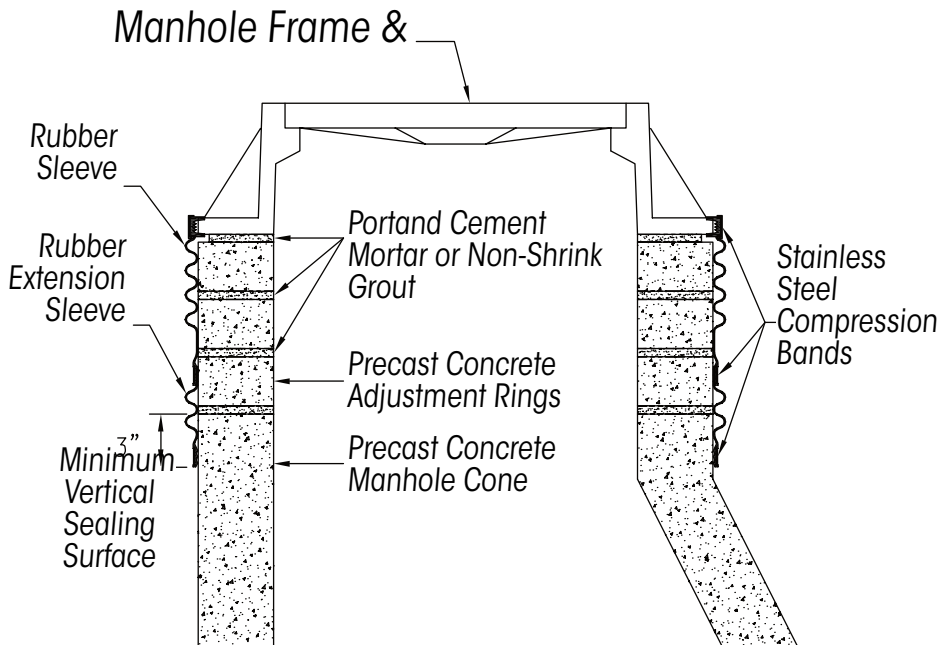

**PRECAST MANHOLE WITH EXTERNAL SEAL**

1. See the chimney height table below for seal and extension combinations needed to span from the frame to the top of the cone on manholes with various chimney heights. Frame offsets or diameter differentials will reduce these span heights.
2. The top of the cone shall have a minimum of 3" high vertical sealing surface that is smooth and free of any form offsets or excessive honeycomb.
3. External Chimney Seals Shall Be Installed On All Sanitary Manholes.
4. External Chimney Seals Shall Be The "X-85 Seal" As Manufactured By Cretex Specialty Products.

**CHIMNEY HEIGHT TABLE**

TO SPAN HEIGHTS OF:	COMBINATIONS OF SEALS AND EXTENSIONS
0" to 12"	STD X-85 Seal
Over 12"	Extension As Needed
Add 7" of coverage for each additional Extension.	

EXTERNAL MANHOLE CHIMNEY SEAL W/EXTENSIONS PRECAST

**ORDERING AND REPORT FORM**

Community: \_\_\_\_\_ Manhole No: \_\_\_\_\_  
 Location: \_\_\_\_\_ Date: \_\_\_\_\_

Describe any pertinent factors:

\_\_\_\_\_  
 \_\_\_\_\_  
 \_\_\_\_\_  
 \_\_\_\_\_

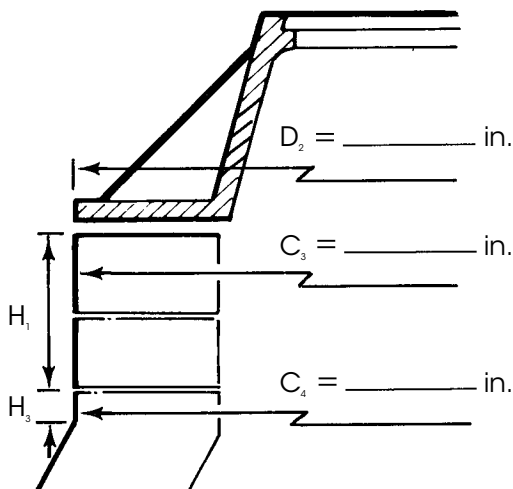

Size Required: \_\_\_\_\_  
 Sleeve Width: \_\_\_\_\_ Standard \_\_\_\_\_ Narrow  
 Extension: \_\_\_\_\_ Yes \_\_\_\_\_ No

## Installation Instructions

1. Recommended New Construction Installation: Construct the manhole chimney to grade as required, allowing for a minimum 3/8 inch thick joint between the frame base flange and top adjusting ring or cone. The area of the cone where the bottom of the sleeve or extension compresses, must be a minimum 1 inch wide, reasonably smooth, vertical and circular surface and be free of any loose material or excessive voids. Non-shrink repair mortar must be used to repair and smooth out defects on this surface.
- 2 Place a thick bed of mortar on the horizontal surface of the cone or top adjusting ring and embed the provided spacers in it at equal spacing. Spacers are not required if the base flange of the casting is 1-1/2 inches or more larger in diameter than the chimney or cone. DO NOT use butyl rubber gasket material such as EZ Stik or Kent Seal in this joint.
- 3 Set the manhole frame on top of these spacers, center it on the chimney or cone, and embed in the mortar course. Rake the mortar free for a minimum depth of 1 inch under the outer edge of the casting base flange and smooth out the joint on the inner surface.
- 4 Grind or fill any imperfections on the edge of the manhole frame base flange and remove any loose rust or scale to provide a reasonably smooth, clean sealing surface. Cut or grind smooth any strengthening ribs that may interfere with the seal or top compression band.

- If an extension is being used, position it first by placing it around the manhole frame and pull it down until the lower sealing band area is positioned on the vertical surface of the cone.
- 5

- If only a seal is being used, place the sleeve around the manhole frame and chimney and pull down to fit the top section of the sleeve over and under the edge of the frame base flange and the lower sealing band area so it is positioned on the chimney or cone. Lubricate the top compression band area of the sleeve with the supplied gasket lube.
- 6

- Place the top compression band around the sleeve and frame base flange with the gear nut to the right. Tighten the band securely using a 5/16 inch nut driver, socket with ratchet wrench or large flat blade screw driver. Check to insure that the band has been compressed and the sleeve is sealed around its entire perimeter.
- 7

- Some surfaces may have irregularities that may require the use of a butyl rubber caulk as a filler material to obtain a watertight seal. In such cases, lift up the bottom of the sleeve or extension, apply the caulk in the area of the surface defect and return it to its normal position.
- 8

- If only a seal is being used, lubricate the bottom band recess area, place the band around the sleeve and into the recess with the gear nut to the right and adjust the sleeve so that the top and bottom bands are parallel. Tighten the lower band using a 5/16 inch nut driver, socket with ratchet wrench or large flat blade screw driver. Check to insure that the sleeve is tight against the surface around its entire perimeter.
- 9

- If an extension is being used, position it so the top of the extension is under the lower sealing band area of the seal and the bands are parallel.
- 10

- Repeat step 9 to tighten the bands and seal the top of the extension/bottom of the seal and the bottom of the extension.
- 11

- Backfill the area immediately around the manhole with selected material using care so as not to damage the installed seal and/or extension.
- 12

**Do not over-tighten**