

ASTM F-894

HIGH-DENSITY SPIROLITE[®] POLYETHYLENE PIPE

Product Data

SPIROLITE[®]

Supplied by:



www.culvert-rehab.com

INDUSTRIAL PIPE FITTINGS, LLC
6020 OSBORN STREET, HOUSTON TX 77033

(F) 713.645.2858
(P) 713.645.2858
TOLL FREE: 800.241.4175

WWW.IPF-PLASSON.COM
EMAIL: SALES@IPF-PLASSON.COM



TABLE of CONTENTS

THE LEADER IN LARGE DIAMETER PLASTIC PIPES	3
PIPE SELECTION	8
PIPE PROPERTIES	12
DEFLECTION CONTROL	15
INSTALLATION	17
APPENDIX	19
SPECIFICATIONS	27

This bulletin is intended to be used as a guide to support the designer in the use of Spirolite® Pipe. It is not intended to be used as installation instructions, and should not be used in place of a professional design engineer. The information contained herein cannot be guaranteed because the conditions of use are beyond our control. The user of this bulletin assumes all risk associated with its use.

THE LEADER IN LARGE DIAMETER PLASTIC PIPE

Spirolite® the leader in plastic pipe technology, manufactures thermoplastic pipe in diameters through 120 inches. Spirolite® pipe, because of the unique processes through which it is manufactured, is the only high density polyethylene system in the United States that truly offers a cost competitive alternative to traditional piping systems for gravity and pressure sanitary sewer

and industrial waste applications. Lightweight Spirolite® pipe offers the ease of a bell and spigot joint design or a plain ended field welded joint that reduces installation time and the corrosion resistance to assure long-term, trouble-free service. Spirolite® pipe also meets the requirements of **ASTM F-894**.

SIZE RANGE

SPIROLITE® PROFILE			
18	21	24	27
30	33	36	1000mm
42	48	54	57
60	66	72	78
84	96	120	

SPIROLITE® HS (closed profile)			
30	36	1000mm	42
48	54	60	66
72	78	84	90

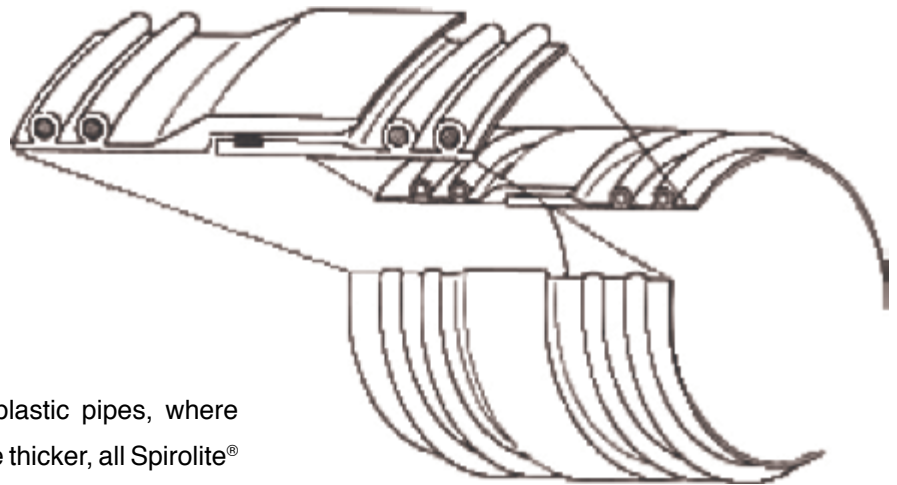

Unlike many conventionally extruded thermoplastic pipes, where inside diameter is decreased as the wall is made thicker, all Spirolite® pipe is manufactured to constant internal diameters. Standard Spirolite® sizes are listed below. Additional sizes through 144" diameter are available on request.

PROFILE WALL CONCEPT: MAXIMUM EFFICIENCY

Spirolite® is manufactured through an exclusive process by which a profile extrusion is continuously wound upon a mandrel. These innovative wall constructions take advantage of geometrically efficient hollow rib profile or closed profile design to minimize pipe weight maximizing stiffness to weight ratio. Each size of Spirolite® pipe

is available in several standard classes, allowing the engineer to choose the profile/class which is the most economical for their specific application. Spirolite® profile wall concepts have been proven by more than 30 years of Spirolite® profile.

PIPE MATERIAL

MANUFACTURED FROM A
**HIGH DENSITY,
 HIGH MOLECULAR
 WEIGHT** POLYETHYLENE

Spirolite® is manufactured from a high density, high molecular weight polyethylene especially designed for engineered piping applications. This material has been used successfully to make pipe for over 30 years. The resin selected for Spirolite® offers the optimum combination of strength, stiffness, toughness, and long-term reliability (see Figure 1). The material is classified by ASTM D-3350 *Standard Specification for Polyethylene Plastics Pipe and Fittings Materials* as having a minimum cell classification of 335444C. Other grades of HDPE and materials may also be selected based on application requirements.

ESCR

Some grades of polyethylene may crack when under stress and in contact with certain chemical substances. This phenomenon is known as environmental stress cracking. Spirolite® pipe is made from stress-crack resistant materials which, when tested under the most severe ESCR test conditions (ASTM D-1693, Condition C), produce a result that far exceeds the ASTM D-3350 requirements for the highest-rated pipe materials.

WEATHERABILITY

Although Spirolite® pipe has been primarily designed for buried applications, it is weather resistant—it may be stored or used for years in direct exposure to the natural elements. The pipe compound contains a minimum of 2% carbon black, as specified by the ASTM D-3350 for weather resistant (Class C) grades. This additive screens out the sun's potentially damaging ultraviolet rays and preserves the pipe's properties.

CHEMICAL & CORROSION RESISTANCE

The outstanding chemical and corrosion resistance of Spirolite® pipe makes it ideal for sanitary sewer and a wide variety of industrial waste disposal applications. It will not rust or decay or support bacteriological growth and is not subject to electrolytic or galvanic corrosion. **Neither hydrogen sulfide nor the resulting sulfuric acid commonly found in sanitary sewers has any effect on the physical properties of Spirolite® pipe.** A comprehensive chemical resistance brochure is available on request.

Figure 1: CELL CLASSIFICATION DESCRIPTIONS PER ASTM D-3350*

CELL CLASSIFICATION FOR SPIROLITE BASE RESIN PE 3408	PROPERTY	CELL CLASSIFICATIONS LIMITS
3	Density per ASTM D-1505, gm/cm ³	0.941—0.955
4	Melt Index per ASTM D-1238, gm/10 min	< 0.15
5	Flexural Modulus per ASTM D-790, psi	110,000—160,000
4	Tensile Strength per ASTM D-638, psi	3,000—3,600
6	Enviornmental Stress Crack Resistance per ASTM D-1693, hours in 100% Iegpal and PENT per ASTM F-1473, hours	ESCR > 5000 PENT > 100
4	Hydrostatic Design Basis per ASTM D-2387, psi	1600
C	Color & Ultraviolet Stabilizer	>2% Carbon Black

*Base resin. Pipe values may vary. HDB established when compounded with the proper color concentrate. Cell classifications are minimum cell values. Resins with higher cell values may be used.

TEMPERATURE

Spirolite® material has been selected to satisfy the broadest range of commonly encountered operating temperatures. Its working temperature range depends on specific circumstances, but generally extends from about -40°F to 140°F. As with all thermoplastics, an increase in temperature tends to reduce stiffness and strength but improves ductility. With decreasing temperature, the opposite effects occur. When working outside the ambient temperature range, these effects should be taken into consideration by the designer.

A characteristic of polyethylene is its relatively high coefficient of thermal expansion/contraction. However, for buried applications, exposure to variable temperatures is generally not a design concern because of the restraining action of the surrounding soil and the inherent stress absorbing capabilities of the pipe material.



FEATURES

LONG LENGTHS

Figure 2: FEWER JOINTS PER INSTALLED LENGTH

PROJECT LENGTH (ft.)	NUMBER OF JOINTS				
	50' LENGTH*	20' LENGTH**	13' LENGTH	8' LENGTH	4' LENGTH
5000	100	250	385	625	1250
10000	200	500	769	1250	2500
15000	300	750	1154	1875	3750

*Over 20' lengths are produced by Spirolite® HS only.

**Over 72" I.D. is produced in 19' laying lengths

Spirolite® Profile pipe is produced in standard 20' laying lengths up to 72" I.D.* while **Spirolite® HS** (closed profile) pipe is produced in standard 50' laying lengths. This allows the contractor to operate at maximum efficiency by reducing the number of joints that have to be assembled. The benefits can be significant. Many contractors have found they can install 20% - 30% more Spirolite® pipe per day than a similar size pipe made from traditional materials. The dramatic difference in the number of joints is also important when considering the cost of jobsite testing. As shown in Figure 2 on the left, the number of Spirolite® joints which must be laid and tested, and remain infiltration free for the life of the piping system, is substantially lower than that of other pipes supplied in shorter lengths.

By request, **Spirolite® Profile** pipe and while **Spirolite® HS** (closed profile) pipe may be produced in shorter lengths for projects where severe ground conditions may limit the amount of trench that can be held open.

LIGHTWEIGHT

The unit weight of Spirolite® pipe is considerably less than that of traditional pipe products. The savings resulting from the use of a lightweight piping system can be significant. Shipping costs are reduced. Installation equipment may be lighter and thus less expensive to operate. Jobsite handling efficiency is also increased. Many contractors have found it possible to drastically reduce, or in some cases, even eliminate the need for expensive lifting equipment to lower the pipe into the trench. A comparison of various pipe materials and their respective weights is shown in Figure 3.

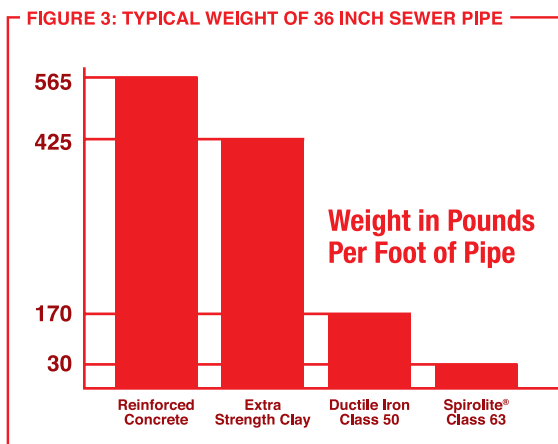

TOUGH AND DURABLE

Spirolite® is rugged. It withstands stresses that would normally damage conventional piping products. Its resistance to cracking and breakage through customary jobsite handling eliminates the need to order extra pipe.

JOINING

Spirolite® pipe may be joined by two alternative techniques, each employing the ease of bell and spigot assembly. These are rubber gaskets and thermal weldings. Together, they allow the specifier the option of selecting that method which is best suited to the application.

RUBBER GASKET JOINT



The Spirolite® gasket is designed to meet ASTM F-477. This easily assembled joint is perfect for sanitary sewer and most industrial waste applications and is available in 18" through 84" diameter Spirolite®. The gasket will not "fishmouth" or roll out of its groove when homed. Because of its unique profile shape, the gasket provides dual sealing: a compression seal against exfiltration and a combination of compression and hydraulic seal against infiltration. This provides double protection. The hydraulic seal is energized by external pressure, thus, it becomes tighter with increasing infiltration pressure. This unique design is superior to an O-ring seal which provides only a compression seal. The Spirolite® joint passes standard air or hydrostatic field testing with ease

THERMAL WELDED JOINT

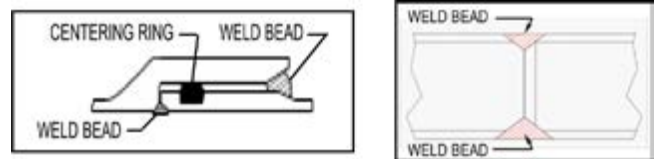

and is designed with ASTM D-3212 Joints for Drain and Sewer Plastic Pipes Using Flexible Elastomeric Seals. Infiltration rates not to exceed 50 gallons/inch of diameter/mile/day may be specified for the Spirolite® gasket joint. Recommended assembly procedures for the gasket joint are given in Spirolite® Technical Bulletin TB-100. The Spirolite® thermal welded joint is used primarily of applications where contact with exotic effluents is anticipated. Using a portable field extruder, a bead of polyethylene is extruded and fused to the juncture of the bell and spigot for Spirolite® Profile or the juncture of plain end pipe Spirolite® HS (closed profile) to form a homogenous joint which is absolutely leak proof. The weld bead may be placed on the inside or outside of the pipe or both.

MANHOLES AND FITTINGS

For complete corrosion-resistant systems, Spirolite® manholes are available. These manholes can be fabricated to permit connection to Spirolite® pipe, as well as traditional piping materials. Spirolite® pipe can also be connected to traditional types of manholes. See Spirolite® Technical Bulletin TB-101 for available connection options. A full range of fittings are available for use with Spirolite® pipe. All standard fittings are designed with bell and spigot end configurations for easy assembly to Spirolite® pipe in the field. In addition to standard fittings such as elbows, wyes, tees, flanges, and lateral taps, Spirolite® also has the capability to custom fabricate those one-of-a-kind that may be required for special job conditions.



Spirolite®

FLOW CHARACTERISTICS

EQUATION 1

$$Q = \frac{1.486}{N} \cdot AR^{2/3} \cdot S^{1/2}$$

WHERE:

Q = flow (ft.³/sec.)
N = manning roughness coefficient
A = flow area of pipe (ft.²)
R = hydraulic radius (ft.)=D/4
 where D = pipe inside diameter (ft.)
S = slope (feet/foot)

Being made of high-density polyethylene, all Spirolite® products result in excellent hydraulics, superior to those of conventional materials. Spirolite® products minimize flow disturbance due to sedimentation and slime build-up by providing a smooth, non-polar and anti-adhesive inner surface.

Thus, Spirolite® pipe offers the potential for use of smaller diameter and/or reduced slopes to accomplish given flow requirements. The Manning coefficient of Spirolite® pipe for clean water at ambient temperatures is 0.009.

PIPE SELECTION

Spirolite® pipe is manufactured in four standard ring stiffness classes. In preparing a specification, the designer selects a class of pipe appropriate for the application. The following tables may be used to assist the designer in making the selection. It is important that the designer perform all necessary calculations to verify the adequacy of a given class of pipe and be acquainted with all assumptions and installation requirements. Other design methods may be applicable.

MANUFACTURED in
FOUR STANDARD
RING STIFFNESS
CLASSES

The design of HDPE pipe for subsurface applications is typically based on the following performance limits: (1) wall crush strength, (2) constrained buckling resistance, and (3) deflection. Equations for these performance limits are given in the Appendix and were used to produce Table 1 and Table 2 (on the following page). The suitability of a class of pipe for installation at a given depth depends on the installation achieving the design E' and on the pipe being installed in accordance with ASTM D-2321 and the Spirolite® Installation Guide. The designer is advised to review the applicability of these equations to each use of Spirolite®.

The classes and depths shown in the tables are based on a design soil weight (dry or saturated) of 120 lbs/ft³ and an applied H-20 live load. (Where live load is present, Spirolite® pipe normally requires a minimum depth of cover of one pipe diameter or three feet, whichever is greater. Where this condition can not be met, please consult Industrial Pipe Fittings). The earth load for calculating crush resistance was found using the arching coefficients given in Figure 10. The prism load was used for buckling and deflection calculations. Deflection was calculated using 75% of the E' value given at the top of the respective column, a deflection lag factor of 1.5 and a deflection limit of 5%. Buckling was calculated using the E' value listed and a long-term pipe modulus value of 28,250 psi. Buckling resistance was considered only for pipe subjected to ground water, as buckling is normally not a controlling factor for dry ground installations in the range of depths given in the tables. A safety factor of two was applied to the crush and buckling values.

BURIAL ABOVE GROUND WATER LEVEL

Table 1 is based on calculations made assuming the ground water level is always below pipe grade elevation. For other sizes, and burial depths or conditions not listed, consult with Industrial Pipe Fittings. (Continue to the next page for Table 1).

TABLE 1: SPIROLITE® PIPE CLASS SELECTION FOR BURIAL ABOVE THE GROUND WATER LEVEL

Pipe Diameter		18-INCH			21-INCH			24-INCH			27-INCH			30-INCH			33-INCH			36-INCH			42-INCH		
E'		1K	2K	3K	1K	2K	3K	1K	2K	3K	1K	2K	3K	1K	2K	3K	1K	2K	3K	1K	2K	3K	1K	2K	3K
Depth of Cover (ft.)	2	40	40	40	40	40	40	40	40	40	40	40	40	40	40	40	40	40	40	40	40	40	40	40	40
	4	40	40	40	40	40	40	40	40	40	40	40	40	40	40	40	40	40	40	40	40	40	40	40	40
	6	40	40	40	40	40	40	40	40	40	40	40	40	40	40	40	40	40	40	40	40	40	40	40	40
	8	40	40	40	40	40	40	40	40	40	40	40	40	40	40	40	40	40	40	40	40	40	40	40	40
	10	40	40	40	40	40	40	40	40	40	40	40	40	40	40	40	40	40	40	40	40	40	40	40	40
	12	40	40	40	40	40	40	40	40	40	40	40	40	40	40	40	40	40	40	40	40	40	40	40	40
	14	40	40	40	40	40	40	40	40	40	40	40	40	40	40	40	40	40	40	40	40	40	40	40	40
	16	40	40	40	40	40	40	40	40	40	40	40	40	40	40	40	40	40	40	40	40	40	40	40	40
	18	40	40	40	40	40	40	40	40	40	40	40	40	40	40	40	40	40	40	40	40	40	40	40	40
	20	63	40	40	100	40	40	100	40	40	100	40	40	160	40	40	160	63	63	160	63	63	160	63	63
	22	160	40	40	160	40	40		40	40		40	40		40	40		63	63		63	63		63	63
	24		40	40		40	40		40	40		63	63		63	63		63	63		100	100		100	100
	26		40	40		40	40		63	63		63	63		100	100		100	100		100	100		100	100
	28		40	40		40	40		63	63		63	63		100	100		100	100		100	100		160	160
	30		40	40		40	40		100	100		100	100		100	100		100	100		100	100		160	160
	32		40	40		100	100		100	100		100	100		160	160		160	160		160	160		160	160
	34		40	40		100	100		100	100		160	160		160	160		160	160		160	160		160	160
	36		40	40		100	100		100	100		160	160		160	160		160	160		160	160		160	160
38		100	100		100	100		100	100		160	160		160	160								160	160	

TABLE 1: SPIROLITE® PIPE CLASS SELECTION FOR BURIAL ABOVE THE GROUND WATER LEVEL (continued)

Pipe Diameter		48-INCH			54-INCH			60-INCH			66-INCH			72-INCH			84-INCH			96-INCH		
E'		1K	2K	3K	1K	2K	3K	1K	2K	3K	1K	2K	3K	1K	2K	3K	1K	2K	3K	1K	2K	3K
Depth of Cover (ft.)	2	40	40	40	40	40	40	40	40	40	40	40	40	40	40	40	40	40	40	40	40	40
	4	40	40	40	40	40	40	40	40	40	40	40	40	40	40	40	40	40	40	40	40	40
	6	40	40	40	40	40	40	40	40	40	40	40	40	40	40	40	40	40	40	40	40	40
	8	40	40	40	40	40	40	40	40	40	40	40	40	40	40	40	40	40	40	40	40	40
	10	40	40	40	40	40	40	40	40	40	40	40	40	40	40	40	40	40	40	40	40	40
	12	40	40	40	40	40	40	40	40	40	40	40	40	40	40	40	40	40	40	40	40	40
	14	40	40	40	40	40	40	40	40	40	40	40	40	40	40	40	40	40	40	40	40	40
	16	40	40	40	63	63	63	63	63	63	63	63	63	63	63	63	40	40	40	63	63	63
	18	63	63	63	63	63	63	63	63	63	63	63	63	63	63	63	63	63	63	63	63	63
	20		100	100		100	100		100	100		63	63		63	63		63	63		63	63
	22		100	100		100	100		100	100		100	100		100	100		63	63		63	63
	24		100	100		100	100		100	100		100	100		100	100		100	100		63	63
	26		160	160		100	100		100	100		100	100		100	100		100	100		100	100
	28		160	160		100	100		160	160		100	100		100	100		100	100		100	100
	30		160	160		160	160		160	160		160	160		100	100		100	100		100	100
	32		160	160		160	160		160	160		160	160		160	160		100	100		100	100
	34		160	160		160	160		160	160		160	160		160	160		100	100		100	100
	36		160	160		160	160		160	160		160	160		160	160		160	160		100	100
38					160	160			160			160			160			160			160	

See page 10 and page 20, regarding minimum depth of cover requirement when live load is present.

BURIAL BELOW GROUND WATER LEVEL

Table 2 (on the following page) is based on calculations assuming the ground water level is at the ground surface. Table 2 is included as a guide for the designer. The designer normally uses the 100 year flood for a design maximum ground water level. Where that level is below the ground surface, considerable savings may result in using the exact depth of the water for design calculations rather than assuming it is at the ground surface as in Table 2.

Where the ground water is above the pipe, the designer normally checks the adequacy of the weight of the soil backfill to prevent upward floatation or upward buckling of the pipe. For other sizes, and burial depths or conditions not listed, consult with Industrial Pipe Fittings.

Note: Designer should consider buoyancy of pipe in shallow applications.

FIGURE 4: Maximum permissible ground water level for Table 2 is H.

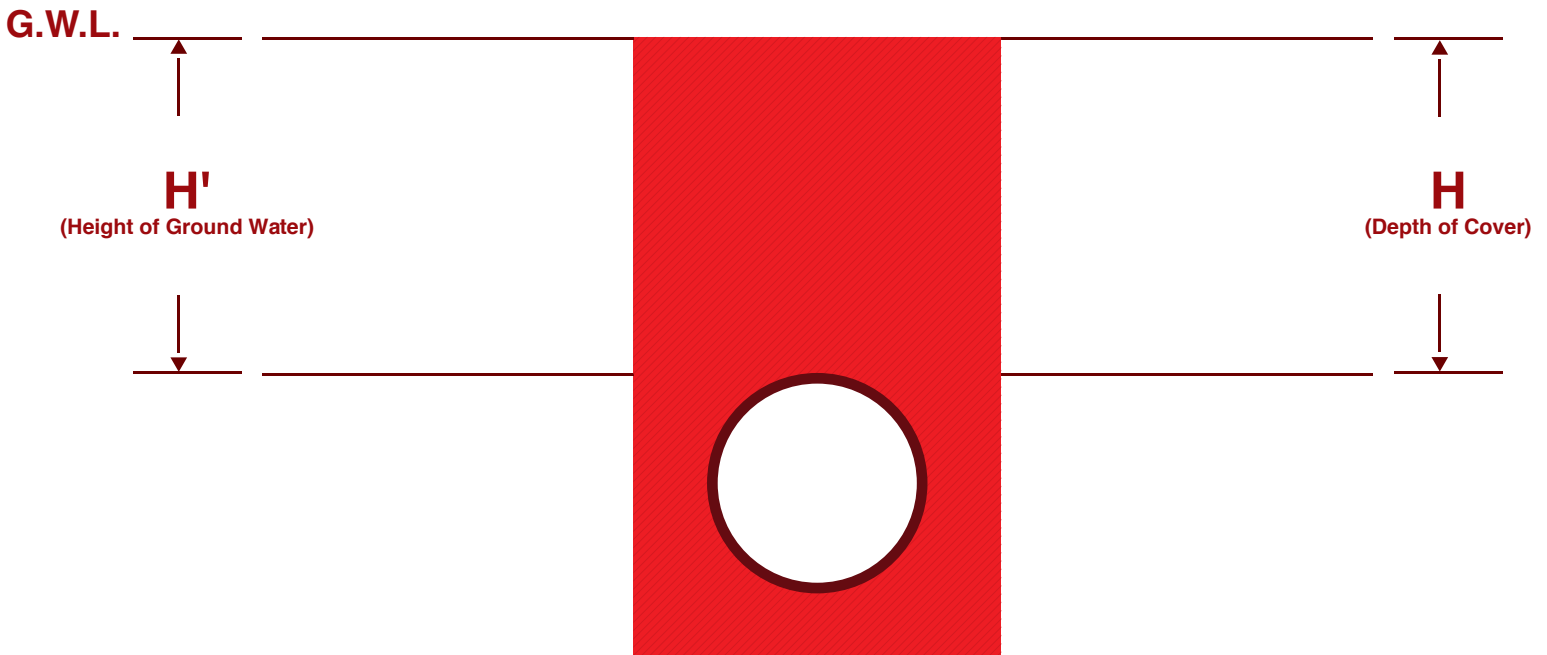

TABLE 2: SPIROLITE® PIPE CLASS SELECTION FOR BURIAL BELOW THE GROUND WATER LEVEL

Pipe Diameter		18-INCH			21-INCH			24-INCH			27-INCH			30-INCH			33-INCH			36-INCH			42-INCH		
E'		1K	2K	3K	1K	2K	3K	1K	2K	3K	1K	2K	3K	1K	2K	3K	1K	2K	3K	1K	2K	3K	1K	2K	3K
Depth of Cover (ft.)	2	40	40	40	40	40	40	40	40	40	40	40	40	40	40	40	40	40	40	40	40	40	40	40	40
	4	40	40	40	40	40	40	40	40	40	40	40	40	40	40	40	40	40	40	40	40	40	40	40	40
	6	40	40	40	40	40	40	40	40	40	40	40	40	40	40	40	40	40	40	40	40	40	40	40	40
	8	40	40	40	40	40	40	40	40	40	40	40	40	40	40	40	40	40	40	40	40	40	40	40	40
	10	40	40	40	40	40	40	40	40	40	40	40	40	40	40	40	40	40	40	40	40	40	40	40	40
	12	40	40	40	40	40	40	40	40	40	63	40	40	63	40	40	40	40	40	63	40	40	100	40	40
	14	40	40	40	40	40	40	63	40	40	63	40	40	63	40	40	63	40	40	100	40	40	100	40	40
	16	40	40	40	40	40	40	63	40	40	100	40	40	100	40	40	100	40	40	100	40	40	100	63	40
	18	40	40	40	63	40	40	100	40	40	100	40	40	100	63	40	100	40	40	160	63	40	160	63	40
	20	63	40	40	100	40	40	100	40	40	100	63	40	160	63	40	160	63	63	160	63	63	160	100	63
	22	160	40	40	160	40	40		63	40		63	40		63	40		63	63		100	63		100	63
	24		40	40		40	40		63	40		63	63		63	63		100	63		100	100		100	100
	26		40	40		40	40		63	63		63	63		100	100		100	100		100	100		100	100
	28		40	40		40	40		63	63		100	63		100	100		100	100		100	100		160	160
	30		40	40		63	40		100	100		100	100		100	100		100	100		100	100		160	160
	32		40	40		100	100		100	100		100	100		160	160		160	160		160	160		160	160
	34		40	40		100	100		100	100		160	160		160	160		160	160		160	160		160	160
	36		40	40		100	100		100	100		160	160		160	160		160	160		160	160		160	160
38		100	100		100	100		100	100		160	160		160	160								160	160	

TABLE 2: SPIROLITE® PIPE CLASS SELECTION FOR BURIAL BELOW THE GROUND WATER LEVEL (continued)

Pipe Diameter		48-INCH			54-INCH			60-INCH			66-INCH			72-INCH			84-INCH			96-INCH		
E'		1K	2K	3K	1K	2K	3K	1K	2K	3K	1K	2K	3K	1K	2K	3K	1K	2K	3K	1K	2K	3K
Depth of Cover (ft.)	2	40	40	40	40	40	40	40	40	40	40	40	40	40	40	40	40	40	40	40	40	40
	4	40	40	40	40	40	40	40	40	40	40	40	40	40	40	40	40	40	40	40	40	40
	6	40	40	40	40	40	40	63	40	40	63	40	40	63	40	40	100	40	40	63	40	40
	8	63	40	40	63	40	40	63	40	40	100	40	40	100	40	40	100	40	40	100	63	40
	10	63	40	40	100	40	40	100	40	40	100	40	40	100	63	40	100	63	40	160	63	40
	12	100	40	40	100	40	40	100	63	40	160	63	40	160	63	40	160	100	63	160	100	63
	14	100	63	40	160	63	40	160	63	40	160	100	63	160	100	63		100	63		100	63
	16	160	63	40	160	100	63	160	100	63	160	100	63		100	63		100	100		160	100
	18	160	100	63	160	100	63		100	63		100	63		100	100		160	100		160	100
	20		100	100		100	100		100	100		160	100		160	100		160	100		160	160
	22		100	100		100	100		160	100		160	100		160	100		160	160			160
	24		100	100		160	100		160	100		160	100		160	100			160			160
	26		160	160		160	100		160	100		160	100		160	160			160			160
	28		160	160		160	100		160	160			160			160			160			160
	30		160	160		160	160			160			160			160			160			
	32		160	160		160	160			160			160			160						
	34		160	160			160			160			160			160						
	36			160			160			160			160									
38						160			160													

Note: a) See text page 10 and page 20, regarding minimum depth of cover requirement when live load is present.
 b) Depth of cover values given above may not be adequate to prevent floatation of submerged pipe. See text page 9.

PIPE PROPERTIES

The following tables provide nominal dimensions and properties for Spirolite® pipe. Figure 5 shows a typical cross section of each profile and its derived properties.

Note: "Se" is the effective wall thickness required in a solid wall section yielding the same moment of inertia.

FIGURE 5: CROSS SECTION OF SPIROLITE® PIPE



TABLE 3: SPIROLITE® PIPE NOMINAL DIMENSIONS AND PROPERTIES CLASS 40

I.D. (In.)	Allowable Crush Load (Lb./Ft. ²)*	P (Period) (in.)	H (Wall Height) (in.)	S (Wall) (in.)	Ø (Core Dia) (in.)	I (Wall Moment) (In. ⁴ /In.)*	Se (Effective Wall) (in.)	A (Average Profile Area) (In. ² /in.)*	Z (Centroid) (in.)
18	2854	5.50	1.47	0.21	1.18	0.031	0.808	0.260	0.30
21	2498	5.50	1.47	0.21	1.18	0.031	0.808	0.260	0.30
24	2221	5.50	1.47	0.21	1.18	0.031	0.808	0.260	0.30
27	2125	5.00	1.49	0.21	1.18	0.038	0.859	0.277	0.33
30	2032	5.00	1.53	0.21	1.18	0.047	0.916	0.295	0.36
33	1867	5.70	1.85	0.22	1.57	0.077	1.073	0.299	0.42
36	1784	5.70	1.86	0.23	1.57	0.078	1.079	0.309	0.42
42	1810	5.60	1.92	0.27	1.57	0.095	1.143	0.361	0.44
48	1706	5.50	1.96	0.27	1.57	0.119	1.215	0.386	0.49
54	1579	5.60	2.27	0.27	1.96	0.169	1.375	0.403	0.55
60	1554	5.60	2.32	0.30	1.96	0.194	1.432	0.446	0.57
66	1612	5.40	2.37	0.33	1.96	0.227	1.503	0.496	0.60
72	1577	5.00	2.39	0.33	1.96	0.266	1.570	0.527	0.65
84	1737	5.00	2.55	0.43	1.96	0.369	1.745	0.673	0.72
96	1731	4.20	2.59	0.43	1.96	0.474	1.891	0.762	0.81

*PROPERTIES ARE BASED ON MINIMUM PROFILE DIMENSIONS.

TABLE 4: SPIROLITE® PIPE NOMINAL DIMENSIONS AND PROPERTIES CLASS 63

I.D. (In.)	Allowable Crush Load (Lb./Ft. ²)*	P (Period) (in.)	H (Wall Height) (in.)	S (Wall) (in.)	Ø (Core Dia) (in.)	I (Wall Moment) (In. ⁴ /In.)*	Se (Effective Wall) (in.)	A (Average Profile Area) (In. ² /in.)*	Z (Centroid) (in.)
18	2854	5.50	1.47	0.21	1.18	0.031	0.808	0.260	0.30
21	2586	5.40	1.49	0.21	1.18	0.035	0.842	0.270	0.32
24	2486	5.10	1.53	0.21	1.18	0.048	0.912	0.293	0.36
27	2455	4.70	1.57	0.21	1.18	0.061	0.985	0.322	0.41
30	2233	5.70	1.88	0.25	1.57	0.081	1.091	0.329	0.42
33	2237	5.70	1.92	0.27	1.57	0.094	1.137	0.359	0.44
36	2155	5.50	1.94	0.27	1.57	0.107	1.182	0.374	0.47
42	2134	4.60	1.98	0.27	1.57	0.146	1.303	0.427	0.55
48	2018	5.08	2.34	0.32	1.96	0.194	1.432	0.460	0.56
54	1950	5.70	2.39	0.33	1.96	0.238	1.519	0.500	0.61
60	1956	4.80	2.41	0.33	1.96	0.294	1.622	0.552	0.68
66	2147	4.70	2.52	0.42	1.96	0.356	1.729	0.664	0.71
72	2138	4.40	2.56	0.42	1.96	0.427	1.828	0.718	0.77
84	2287	4.00	2.70	0.52	1.96	0.577	2.013	0.890	0.86
96	2637	4.00	2.98	0.80	1.96	0.766	2.208	1.170	0.91

TABLE 5: SPIROLITE® PIPE NOMINAL DIMENSIONS AND PROPERTIES CLASS 100

I.D. (In.)	Allowable Crush Load (Lb./Ft. ²)*	P (Period) (in.)	H (Wall Height) (in.)	S (Wall) (in.)	Ø (Core Dia) (in.)	I (Wall Moment) (In. ⁴ /In.)*	Se (Effective Wall) (in.)	A (Average Profile Area) (In. ² /in.)*	Z (Centroid) (in.)
18	3147	4.90	1.51	0.21	1.18	0.044	0.893	0.288	0.35
21	3089	4.30	1.55	0.21	1.18	0.059	0.980	0.324	0.41
24	3334	3.80	1.61	0.25	1.18	0.077	1.066	0.395	0.44
27	2686	5.60	1.92	0.27	1.57	0.097	1.143	0.361	0.44
30	2666	4.80	1.94	0.27	1.57	0.119	1.224	0.394	0.50
33	2627	4.70	1.98	0.27	1.57	0.144	1.296	0.423	0.54
36	2692	4.40	2.02	0.29	1.57	0.171	1.363	0.470	0.58
42	2472	5.20	2.37	0.33	1.96	0.234	1.518	0.504	0.61
48	2470	4.50	2.41	0.33	1.96	0.305	1.648	0.569	0.70
54	2705	4.20	2.52	0.42	1.96	0.387	1.777	0.696	0.74
60	2712	4.00	2.58	0.42	1.96	0.485	1.905	0.770	0.83
66	2830	4.00	2.69	0.51	1.96	0.571	2.006	0.880	0.86
72	2987	4.00	2.82	0.62	1.96	0.678	2.120	1.010	0.89
84	3385	4.00	3.14	0.94	1.96	0.921	2.342	1.330	0.98
96	3663	4.00	3.45	1.25	1.96	1.210	2.560	1.640	1.08

*PROPERTIES ARE BASED ON MINIMUM PROFILE DIMENSIONS.

TABLE 6: SPIROLITE® PIPE NOMINAL DIMENSIONS AND PROPERTIES CLASS 160

I.D. (In.)	Allowable Crush Load (Lb./Ft. ²)*	P (Period) (in.)	H (Wall Height) (in.)	S (Wall) (in.)	Ø (Core Dia) (in.)	I (Wall Moment) (In. ⁴ /In.)*	Se (Effective Wall) (in.)	A (Average Profile Area) (In. ² /in.)*	Z (Centroid) (in.)
18	3982	4.80	1.63	0.25	1.18	0.071	1.033	0.369	0.42
21	4249	3.80	1.67	0.27	1.18	0.096	1.135	0.440	0.48
24	3257	5.10	1.96	0.27	1.57	0.124	1.238	0.397	0.50
27	3227	4.70	2.00	0.27	1.57	0.157	1.327	0.436	0.56
30	3425	3.70	2.02	0.29	1.57	0.194	1.422	0.508	0.62
33	3034	5.30	2.37	0.33	1.96	0.232	1.510	0.500	0.61
36	3041	4.70	2.39	0.33	1.96	0.276	1.594	0.541	0.66
42	3358	4.30	2.52	0.42	1.96	0.380	1.767	0.689	0.74
48	3363	4.00	2.59	0.43	1.96	0.491	1.913	0.780	0.83
54	3661	4.00	2.76	0.58	1.96	0.616	2.056	0.950	0.87
60	3937	4.00	2.94	0.74	1.96	0.764	2.204	1.130	0.92
66	4223	4.00	3.14	0.94	1.96	0.921	2.342	1.330	0.98
72	4466	4.00	3.34	1.14	1.96	1.100	2.482	1.530	1.04
84	4751	4.00	3.70	1.50	1.96	1.497	2.741	1.890	1.18
96	4946	4.00	4.05	1.85	1.96	1.995	3.006	2.240	1.33

*PROPERTIES ARE BASED ON MINIMUM PROFILE DIMENSIONS.

TABLE 7: SPIROLITE® HS PIPE NOMINAL DIMENSIONS

SPIROLITE® HS (Closed Profile)				
Nominal Pipe ID	Minimum OD (Min. Stiffness)	Maximum OD (Max. Stiffness)	Minimum Class	Maximum Class
30"	33.9	35.3	40	400+
36"	39.9	41.3	40	400+
1000mm	43.3	44.7	40	400+
42"	45.9	47.3	40	400+
48"	51.9	53.9	40	400+
54"	57.9	60.6	40	400+
60"	63.9	67.3	40	400+
66"	69.9	74	40	400+
72"	75.9	80.8	40	400+
78"	81.9	86.8	40	400+
84"	87.9	94.2	40	400+
90"	93.9	101	40	400+

DEFLECTION CONTROL

A realistic approach to deflection control in flexible pipe installations involves assessment of the deflection occurring during installation and due to the service loads, i.e. soil and superimposed loading.

The placement and compaction of bedding material tend to deform plastic pipe, at times causing more deflection than the service load. The lateral forces acting on a pipe during the compaction of the embedment material between the pipe's invert and springline tend to produce a slight increase in the pipe's vertical diameter ("rise"). Rise can offset load deflection.

Because a flexible conduit interacts with the surrounding soil, the nature of the pipe embedment material and the quality of its placement are important to the control of deflection. Some conduit deflection is natural, and is essential to the development of necessary soil support. The maximum deflection at any point along a pipe must be limited to safeguard its performance capabilities (such as joint tightness) and to protect pipe walls from excessive straining. One of the key objectives in the selection and installation of a flexible pipe is deflection control. Spirolite® can withstand large amounts of deflection because of its ductility and ability to relieve stress under load. Common design practice is to limit long term deflection to 7.5%.

COMMON DESIGN PRACTICE IS TO
LIMIT LONG TERM DEFLECTION TO 7.5%

The primary contributor to deflection control is the support provided by the embedment material. Support is the result of mobilization of passive resistance in the embedment material during horizontal deflection of the pipe. The amount of support is measured by and directly proportional to a constant known as the modulus of soil reaction (E'). Values of the modulus of soil reaction are given in Figure 7.

In situ soil stiffness may influence the modulus of soil reaction value. The designer should consider this for applications in soils having a low capacity for lateral resistance.

The effect of pipe deflection of various levels of side support versus pipe ring stiffness is illustrated in Figure 6. Note that, with a modulus of soil reaction of 1000 psi at a burial depth of 10 feet, there is virtually no difference in the amount of anticipated deflection regardless of pipe class. A Class 100 pipe buried to a depth of 10 feet may, depending on the quality of the pipe's embedment (E') deflect substantially more than a Class 40 pipe buried to a depth of 16 feet. The greater E' enables the more flexible pipe, under substantially greater load, to see considerably less deflection. Studies and extensive field experience show this to be the case and indicate that the vertical deflection of buried flexible pipes is about equal to the vertical compression (soil strain) of the pipe's sidefill.

FIGURE 6

VERTICAL DEFLECTION (%)*			
	E'=1000	E'=2000	E'=3000
Depth of Cover =10'	%	%	%
Class 40	2.8	1.4	.9
Class 63	2.8	1.4	.9
Class 100	2.7	1.4	.9
Depth of Cover =16'	%	%	%
Class 40	4.0	2.0	1.4
Class 63	4.0	2.0	1.3
Class 100	4.0	2.0	1.3

*(1) 36" Pipe

*(2) Soil Weight = 120 lb./ft.³

*(3) With H 20 loading

FIGURE 7: VALUES OF E' FOR SPIROLITE® PIPE

CLASS ASTM D-2321	SOIL TYPE FOR PIPE BEDDING MATERIAL (UNIFIED CLASSIFICATION SYSTEM*1)	DUMPED	SLIGHT 85% STD. PROCTOR*3 < 40% REL. DEN.*4	MODERATE 85-95% STD. PROCTOR 40-70% REL. DEN.	HIGH >95% STD. PROCTOR >70% REL. DEN.
I	Crushed Rock Manufactured angular, granular material with little or no fine. (1/4" - 1 1/2")	1,000	3,000	3,000	3,000
II	COARSE-GRAINED SOILS (with little or no fines) GW, GP, SW, SP*2, containing less than 12 percent fines (maximum particle size 1 1/2")	NR	1,000	2,000	3,000
III	COARSE-GRAINED SOILS (with fines) GM, GC, SM, SC*2 containing more than 12 percent fines (maximum particle size 1 1/2")	NR	NR	1,000	2,000
IV (a)	FINE-GRAINED SOIL (LL<50) Soils with medium to no plasticity CL, ML, ML-CL, with more than 25% coarse-grained particles	NR	NR	1,000*5	2,000*5
IV(b)	FINE-GRAINED SOILS (LL>50) Soils with high plasticity CH, MH, CH-MH FINE-GRAINED SOILS (LL<50) Soils with medium to no plasticity CL, ML, ML-CL with less than 25% coarse-grained particles	NR	NR	NR	NR
	Accuracy in terms of Percentage Deflection	±2	±2	±1	±0.5

*1. ASTM Designation D-2487, USBR Designation E-3

*2. Or any borderline soil beginning with some of these symbols (i.e., GM, GC, GC-SC)

*3. Percent Proctor based on laboratory maximum dry density from test standards using about 12,500 ft.-lb.ft³ (598,000 joules/m³)(ASTM D-698, AASHTO-99, USBR Designation E-11).

*4. Relative Density per ASTM D-2049.

*5. Under some circumstances Class IV(a) soils are suitable as primary initial backfill. They are not suitable under heavy dead loads, dynamic loads, or beneath the water table. Compact with moisture content at optimum or slightly dry of optimum. Consult a Geotechnical Engineer before using.

NOTES

1. Organic soils OL, OM, and PT as well as soils containing frozen earth, debris, and large rocks are not recommended for initial backfill.

2. NR Use not recommended per ASTM D-2321.

3. LL Liquid Limit

4. For shovel-sliced Class I material, E' typically equals 1000.

FIGURE 7 BASED ON: BUREAU OF RECLAMATION VALUES OF E' FOR IOWA EQUATION

INSTALLATION

Spirolite® is a flexible conduit. It can sustain controlled deformation without harmful effect. For burial installations, flexible conduit has many benefits. Soil support forces are mobilized, greatly enhancing the pipe's load carrying capabilities, and concentrated loads are relieved. The strength of flexible pipe/soil systems have been repeatedly demonstrated by numerous laboratory tests and confirmed by extensive field experience.

ATSM D2321 Standard Practice for Underground Installation of Thermoplastic Pipe for Sewers & Other Gravity-Flow Applications and ASTM F 1668 Standard Guide for Construction Procedures for Buried Plastic Pipe are applicable to the installation of Spirolite® Pipe. For specific guidelines, refer to Guide Specification High Density Polyethylene (HDPE) Gravity Drain Pipe (F894 Pipe) in Chapter 7.

Underground Installation of Polyethylene Pipe in Chapter 7 of the PPI Handbook of Polyethylene Piping and Industrial Pipe Fittings No. 914 *Spirolite® Installation Guide*.

The key to a successful installation is achieving stable and permanent support of the pipe. For flexible pipe, adequate side support is as important as proper bedding. Bedding and pipe zone backfill materials should be stable and compactible. Uniform and proper placement of materials around the pipe is necessary to obtain permanent support. See figure 8 and 9 for embedment recommendations. Certain applications may require slightly different embedment. Refer to Industrial Pipe Fittings Bulletin No. 914 *Spirolite® Installation Guide* for a complete discussion of embedment.

EMBEDMENT RECOMMENDATIONS

FIGURE 8:

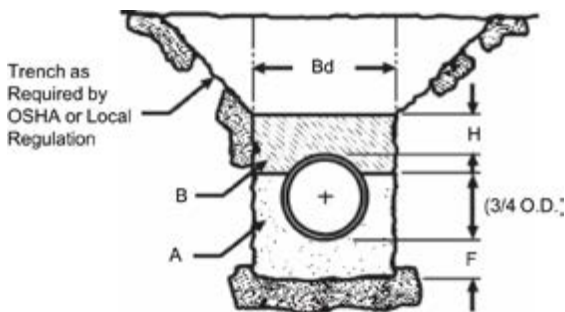

Embedment recommendations for Spirolite® where ground water is always below pipe springline.

A	= 1/4"-1" Class I, II, or III Material	H	= 6" (18-27" Ø Pipe)	
		H	= 12" (30-84" Ø Pipe)	
B	If cover ≤ 16', shovel Class/ compacted Class I or III (90% Std. Proctor) If cover > 16', Compact to 90% Std. Proctor (ASTM D-698) Class I or II only. If cover > 24", use wet bedding installation requirements.	F	= 18" (96-120" Ø Pipe)	
			F	= 4" (18-30" Ø Pipe)
		Bd	F	= 6" (33-84" Ø Pipe)
			F	= 8" (96-120" Ø Pipe)
B	= selected Earth backfill compacted to 90% Std. Proctor	Bd	= O.D. + 18" (18-33" Ø Pipe)	
			Bd	= O.D. + 24" (36-60" Ø Pipe)
			Bd	= O.D. + 36" (66-84" Ø Pipe)
			= O.D. + 48" (96-120" Ø Pipe)	

FIGURE 9:

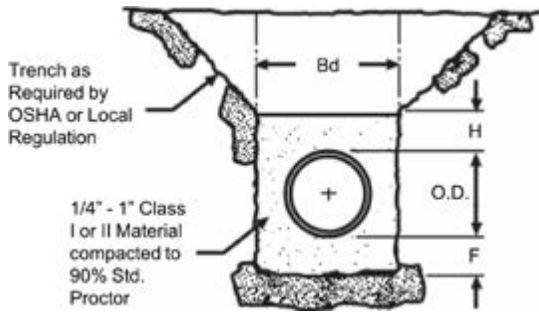

Embedment recommendations for Spirolite® where ground water is sometimes or always above the pipe.

H	= 6" (18-27" Ø Pipe)
	= 12" (30-84" Ø Pipe)
	= 18" (96-120" Ø Pipe)
F	= 4" (18"-30" Ø Pipe)
	= 6" (33-84" Ø Pipe) = 8" (96-120" Ø Pipe)
Bd	= O.D. + 18" (18"-33" Ø Pipe)
	= O.D. + 24" (36"-60" Ø Pipe)
	= O.D. + 36" (66"-84" Ø Pipe)
	= O.D. + 48" (96"-120" Ø Pipe)

Selection of embedment material to be made by owner/owner's engineer on basis of pipe design requirements.

MANHOLE AND FITTINGS CONNECTIONS

Spirolite® pipe can be connected to Spirolite® manholes, fittings or **Spirolite Tomahawk™** waterstops using closure pipes. Closure pipes have smooth OD's and may be cut to length in the field, permitting laying length adjustment and connection to supplied closure bells. For connecting Spirolite® to concrete manholes, refer to TB 101 *Options for Conpirolite pipe to Manholes*. For manholes with A-Lok gaskets, **Spirolite A-Connector™** pipe, which is a special closure pipe, must be used.

A closure pipe is manufactured with standard Spirolite® bell and spigot ends, so that when field cut in half one end of each piece can be joined to a Spirolite® pipe. The cut end is a plain pipe end and it can be joined to a closure bell using a closure gasket. Spirolite® manholes and fittings are normally supplied with closure bells. Closure pipes permit length adjustments.

A-LOCK is a registered trademark of A-Lock Products, Inc.

CLOSURE PIPES HAVE
SMOOTH
 OD'S AND MAY BE CUT
 TO LENGTH IN THE FIELD

APPENDIX

This section provides a detailed approach to selection of the proper class of pipe for a specific subsurface installation. An example of this approach is also included.

The following considerations apply in the selection of Spirolite® as well as other flexible pipes: resistance to crush, resistance to buckling, and resistance to deflection due to construction and service loads.

Selection of a class of Spirolite® pipe generally depends on the crushing resistance of the pipe wall rather than on the anticipated deflection of the pipe. In cases where the pipe is buried beneath the ground-water table, the constrained buckling resistance of the pipe must also be considered. Pipe class has little influence on long term service load deflection in most installations. Deflection is controlled by the enveloping soil stiffness, as shown in the section "Deflection Control."

The Class of Spirolite® pipe selected for a given application should have allowable crush and buckling loads in excess of the service load. The service load includes traffic loads, earth load, and surcharge load.

WALL CRUSH STRENGTH

The allowable crushing load for a confined conduit is determined by the compressive strength of its walls. The allowable crushing loads for all Spirolite® sizes and classes are listed in Tables 3-6. These values have been calculated using the following equation.

EQUATION 2

$$P_c = \frac{288 A S_c}{N D}$$

WHERE:

- P_c = allowable crushing load (lbs./ft.²)
- S_c = long term compressive stress (psi) - 1600 psi at 73.4° F.
- N = safety factor (generally taken as 2)
- A = average profile area (in.²/in.) - See Tables 3-6
- D_o = pipe outside diameter (in.) = pipe inside diameter + 2 times wall height - See Tables 3-6

NOTE: THE CONSTANT IN THIS EQUATION INCLUDES THE APPROPRIATE UNITS COVERSION FACTOR

CONSTRAINED BUCKLING RESISTANCE

Occasionally, when pipe is buried below the groundwater table, wall buckling resistance will govern the class selection of Spirolite® pipe. Constraint of pipe in a trench greatly increases its resistance to wall buckling under hydrostatic load. For a constrained pipe buried to a depth of cover greater than 4 feet, the following equation¹ may be used to determine the allowable buckling pressure.

EQUATION 3

$$P_{wc} = \frac{5.65}{N} \cdot \sqrt{\frac{R B' E' EI}{D_m^3}}$$

WHERE:

$$B' = \frac{1}{1 + 4e^{(-.065H)}}$$

- P_{wc} = allowable constrained buckling pressure (psi)
- H = height of cover (ft.)
- R = buoyancy reduction factor = $(1 - .33 H'/H)$ for $H' < H$
- N = safety factor (generally taken as 2)
- E' = modulus of soil reaction (psi)
- H' = height of groundwater surface above pipe (ft.)
- E = modulus of elasticity of pipe material (psi) (for pipe permanently beneath the water table, E typically equals 28,250 psi. When hydrostatically loaded for less than 3 months out of the year, E may be taken as 42,200 psi.)
- I = moment of inertia of wall section (in.⁴/in.)
- D_m = $(D_i + 2Z)$ mean diameter (in.)
- D_i = inside pipe diameter (in.)
- Z = distance from inner pipe surface to the centroid of the wall section (in.) - See Tables 3-6

¹"Recommendations for Elastic Buckling Design Requirements for Buried, Flexible Pipe." Proceedings, Part 1 AWWA 1982 Annual Conference, "Better Water for the Americas."

HYDROSTATIC COLLAPSE RESISTANCE

In the special case of underwater installations where the pipe is submerged directly in water or other fluids, the pipe's allowable hydrostatic collapse pressure may be determined by equation 4.

EQUATION 4

$$P_w = \frac{24EI}{(1-\mu^2)D_m^3} \cdot \frac{C}{N}$$

WHERE: P_w = allowable hydrostatic collapse pressure of unconstrained pipe (psi)
 E = modulus of elasticity of pipe material (psi) (Ranges from 113,000 psi for short term loading at 73.40F. to 25% of that value for continuous long term loading)

I = moment of inertia of wall section (in.⁴/in.) -See Tables 3-6

μ = Poisson's ratio for pipe material (ranges from about 0.35 for short term loading to 0.48 for long term loading).

D_m = $(D_i + Z)$ mean diameter (in.)

D_i = inside pipe diameter (in.)

Z = distance from inner pipe surface to the centroid of the wall section (in.) See Tables 3-6

C = ovality correction factor as follows:

Ovality	C
1%	0.91
2%	0.84
3%	0.76
4%	0.70
5%	0.64

N = safety factor (generally taken as 2.5)

RING STIFFNESS CONSTANT (RSC)

Pipe's sensitivity to deflection rise during installation is controlled by the pipe's ring stiffness. Ring stiffness is defined in terms of the deflection resulting from the load applied between parallel plates. The Ring Stiffness Constant (RSC) is the value obtained by dividing the parallel plate load pounds per foot of pipe length by the resulting deflection in percent, at 3% deflection. (As described in ASTM F-894.)

EQUATION 5

$$RSC = \frac{6.44EI}{D_m^2}$$

RSC = ring stiffness constant (parallel plate load in pounds per foot of pipe which causes a 1 % reduction in diameter)

WHERE: I = moment of inertia of wall section (in.⁴/in.)-See Tables 3-6

E = short term modulus of pipe material (113,000 psi@ 73.4°F.)

D_m = $(D_i + 2Z)$ mean diameter (in.)

D_i = inside pipe diameter (in.)

Z = distance from inner pipe surface to the centroid of the wall section (in.) See Tables 3-6

The classes are shown in Tables 3-6. All sizes of pipe in the same class will deflect uniformly under parallel plate load, i.e. the same parallel plate load will produce approximately the same percent of deflection in all pipe of a given class. For example, any Class 40 pipe will deflect approximately 2% under an 80 lb/lineal ft. load.

To further illustrate this, consider a Class 40 pipe, which is the most flexible Spirolite® pipe. Although the exact force applied to a flexible pipe during compaction is not easily calculated, it is known that, for ordinary levels of compactive effort, Class 40 pipe possesses adequate stiffness to achieve a beneficial amount of rise while not impeding the installation or creating significant stresses in the pipe wall. Field observation indicates a typical rise of one or two percent in the vertical diameter. However, variations in embedment materials, their placement, and in compactive techniques make it difficult to estimate rise prior to the actual installation.

Beyond initial installation, pipe stiffness plays an insignificant role in controlling deflection.

The nominal ring stiffness constant of a specific Spirolite® pipe can be directly related to the pipe's class designation. That is, a Class 40 pipe has a nominal ring stiffness constant of 40, the RSC of Class 63 is 63, and so forth. The minimum RSC for any diameter of pipe within a class is 90% of the class nominal value*.

ESTIMATING DEFLECTION

Total deflection of a flexible pipe includes both the deflection incurred during installation and the deflection due to soil and superimposed loads. Most proposed relationships for estimating deflection deal only with the latter loads. However, sufficient empirical data exists to make reasonable estimates of total deflection.

A well known relationship for calculating the average vertical deflection in a buried flexible pipe resulting from soil loading only is Spangler's Modified Iowa Equation. Equation 6 is modified and expressed in terms of RSC values and assumes a bedding constant of $K = 0.1$ (for typical bedding support).

The U.S. Bureau of Reclamation (USBR) and others have investigated the load/deflection relationship of

buried flexible pipe. As a result of hundreds of field measurements, and computer analysis, a series of soil reaction (E') values were developed for use with the above Equation. These E' values are useful in estimating the initial deflection resulting from soil loading. They are presented in Figure 7 in terms of the embedment materials.

EQUATION 6

$$\frac{Y}{D_i} = \frac{Y}{D_i} \cdot \frac{(.1)L}{(1.24 (RSC)/D_i) + 0.061 E'}$$

WHERE:

Y = vertical pipe deformation (in.)
D_i = inside pipe diameter (in.)
P = load on pipe (lbs./linear ft.)
RSC = ring stiffness constant (lbs./linear ft.)-See Tables 3-6
E' = modulus of soil reaction (psi) See Figure 7
L = deflection lag factor (Typical values range from 1.0 to 1.50)

LIVE AND DEAD LOADS

In the design of buried pipelines, both earth loads and live loads must be considered for the proper selection of pipe classes. Thus, the total load on a pipe is expressed by the following equation:

EQUATION 7

$$\text{TOTAL LOAD} = \text{SOIL LOAD} + \text{LIVE LOAD}$$

SOIL LOADS

The work of Marston and recent developments with finite element analysis have shown that at a given depth, the vertical soil pressure at the crown of a buried flexible pipe is generally less than the pressure in the soil if no pipe were present (prism condition). This phenomena occurs because the flexible pipe deflects under the load and allows part of the load to be absorbed by soil frictional forces (soil arching).

Spirolite® recommends the use of the soil arching concept for calculating the soil load for analysis of Spirolite® wall crush strength. The soil load as defined in Equation 8 is the product of the prism load and the arching coefficient. The arching coefficient reduces the prism load to a conservative arched soil load value. Figure 10 provides a graphical solution for the arching coefficient.

For evaluations involving the Constrained Buckling and Spangler's Iowa Equation, the value for the modulus of soil reaction (E') was derived using the prism load. Therefore, for evaluations employing the Spangler and Constrained Buckling Equation, an arching coefficient, F, of 1.0 should be used.

EQUATION 8

$$\text{TOTAL LOAD} = (\text{PRISM LOAD}) * \text{ARCHING COEFFICIENT} + \text{LIVE LOAD} \\ = \text{WHF} + \text{L}$$

WHERE: P = total load (lbs./ft)
 W = design unit weight of soil (lbs./ft)
 H = height of cover (ft.)
 F = Arching coefficient (see Figure 10)
 L = live load (see Figure 11)

FIGURE 10: GRAPHICAL SOLUTION TO MARSTON SOIL ARCHING CONCEPT

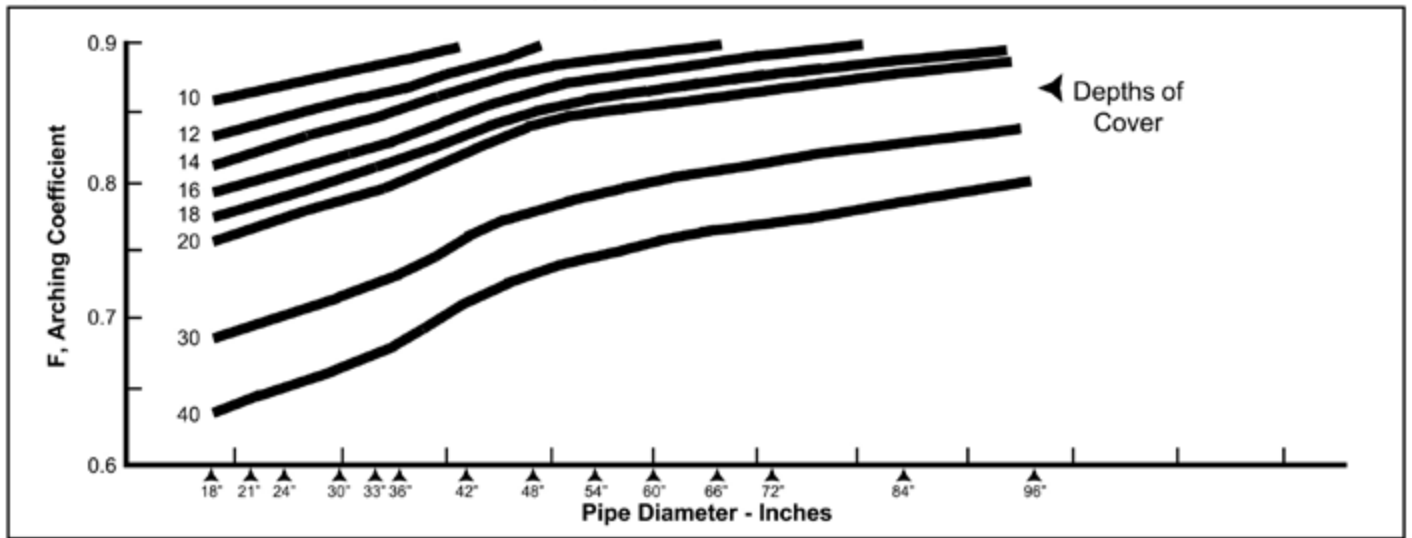

- (1) The Marston Load is calculated. Since specific soil conditions are not always known, ordinary clay ($k_u = 0.13$) was assumed for the calculations. The assumed trench width was ID + 3' for 18" - 42" and ID + 4' for 48" - 96" (Marston formula is given in ASCE Manual No 60, Gravity Sanitary Sewer Design and Construction).
- (2) The prism load is calculated. The prism load equals the product of the unit weight of soil and the depth of cover (ft.)
- (3) Add 40% of the difference between the prism load and the Marston load to the Marston load.

- (4) The arching coefficient is obtained by dividing the quantity obtained in Step 3 by the prism load.
- (5) If the arching coefficient exceeds 0.9, use 1.0 instead. For example, a 36" Spriolite® pipe with 18' of cover in a 6 ft. wide trench with a 120 lb / ft.³ soil design weight. Therefore, the arching coefficient equals:

$$F = \frac{1500 \text{ psf} + 0.4 (2160 - 1500)}{2160 \text{ psf}} = 0.82$$

TRAFFIC LOADS

The vehicular load applied to a buried pipe depends on the depth of cover and the pavement type. Figure 11 gives the theoretical amount of load transferred to the pipe by a standard 20 ton truck (H20 loading) passing over 12" thick, rigid pavement. For flexible pavement or unpaved roads, loads may be calculated using a suitable point load or distributed load equation. Load intensity varies somewhat with the different methods based on the engineering assumptions made when deriving the equations. Equation 9 gives the approximate pressure at the point in the soil under a wheel load with no pavement and thus can be used for flexible pavement.

FIGURE 11: TRAFFIC LOADINGS TRANSFERRED TO THE PIPE (lb/ft²)

Cover (ft)	Transferred Load (lb/ft ²)
1	1800
2	800
3	600
4	400
5	250
6	200
7	175
8	100
10	**

NOTES: (1) Simulates 20 ton truck traffic + impact
 (**) Negligible live load influence
 Source: Handbook of PVC Pipe

EQUATION 9

$$P_L = \frac{I_i W_i}{A_c} \left(1 - \frac{H^3}{(r_T^2 + H)^{2.15}} \right)$$

WHERE: P_L = Vertical pressure acting on pipe crown, lb/ft²
 I_i = Impact factor, typically 1.5 for paved roads,
 2 or higher for unpaved roads
 W_i = Wheel load, lb
 A_c = Contact area, ft²
 r_T = Equivalent radius, ft
 H = Depth to pipe crown, ft

For standard H20 or HS20 highway vehicles, the contact area for dual wheels is assumed to be an 18" by 20" area. Dual wheel loading is 16,000 lbs. The equivalent radius is given by:

$$r_T = \sqrt{\frac{A_c}{\pi}}$$

SHALLOW COVER UNDER LIVE LOADS

Where traffic loads are present, a minimum depth of cover of 18" or one-half the pipe diameter (whichever is greater) is recommended for Spirolite® pipe. However, where the depth of cover is less than 3 feet or one pipe diameter (whichever is greater), the combined bending resistance of the pipe and soil must be sufficient to handle the live load. Thus, Equation 10, which gives the upper limit on the live load, must be satisfied or the depth of cover and/or the pipe class increased. In addition to checking for bending capacity, the designer should also check resistance to crush, buckling, and deflection due to the total load per equations 2, 3, and 6 respectively.

FLOTATION OF SPIROLITE® PIPE

Where pipe is installed with less than one and a half diameters of cover and the groundwater or water level in the pipe trench can rise above the pipe, there is a potential for pipe flotation. The buoyant uplift acting on the pipe due to the displaced volume of water must be less than the hold-down forces due to the soil above the pipe and the weight of the pipe and its contents by a sufficient safety factor. Where there is insufficient cover to prevent flotation, a continuously poured concrete cap can be used to hold the pipe down. For a conservative calculation, the designer may equate the displaced volume of water with the outside diameter of the Spirolite® pipe and ignore the pipe weight. Consult Spirolite® for dimensions and weights, if a more exact calculation is required.

SHALLOW COVER BUCKLING

Normally, the soil weight or concrete cap required to prevent Spirolite® from floating will be sufficient to prevent the pipe crown from excessive upward deflection due to groundwater pressure at the sides of the pipe. In this case, if the groundwater pressure or negative internal pressure in feet of water-head exceeds the height of cover, consult Spirolite®.

CASING, TUNNELS, AND SLIPLINING

When Spirolite® pipe is placed in casings or tunnels, the annular space between the pipe and the casing is normally filled with concrete grout. Grouting is necessary to keep bell and spigot joints together and to enhance the pipe's resistance to buckling. The enhancement depends on the quality of the grout, its placement, and grout strength. Consult Spirolite® for details.

Spirolite® Technical Bulletin 140 *Guidelines for Grout Encasement* describes installation guidelines for casings and tunnels. The designer should insure that the pipe will not float, buckle, or deflect excessively during the

placement of grout. Resistance to grout pressure may be calculated using Equation 4. Grout is normally placed in lifts. Flotation and buckling may be prevented by properly blocking the pipe, placing struts in the pipe, filling it with water, and placing grout in lifts.

EQUATION 10

$$PL \leq \frac{12w (KH)^2}{ND_o} + \frac{7387(I)}{ND_o^2 C} \left(S - \frac{wD_o H}{288A} \right)$$

WHERE:

w = Unit weight of soil, lb/ft²
D_o = Pipe outside diameter, in
H = Cover height, ft
I = Moment of inertia of wall section, in⁴/in
A = Average profile area, in²
C = Outer fiber to wall centroid (C = h - Z), in
Z = Wall centroid, in
S = Material yield strength, lb/in²
N = Safety factor (generally taken as 2)
K = Passive earth pressure coefficient

$$K = \frac{1 + \sin(\emptyset)}{1 - \sin(\emptyset)}$$

∅ = Angle of internal friction, deg

EXAMPLE CALCULATION

This example provides a step-by-step approach for determining which class of Spirolite® is suitable for a specific installation. The example utilizes the three basic pipe properties of wall crush, constrained buckling resistance and deflection to select the proper class of pipe for this particular installation. For this example, we will select a 60" Spirolite® pipe for installation with 18 feet of cover. The pipe will be 9 feet beneath the permanent water table. The native soil is clayey with a design unit weight of 120 pcf. The embedment material chosen for the job is coarse graded sand that is classified Class II per ASTM D 2321. The embedment material will be compacted to 90% Standard Proctor Density with an average E' value of 2000 psi (See Figure 8).

1. First determine the total load on the pipe. Use the following values for this example:

Unit weight of soil	W = 120 pcf
Height of cover	H = 18ft.
Live Load	L = 0 psf
Soil Arching Factor	F = .86 (See Figure 10)

Use Equation 8 to calculate the total load on the pipe:

$$\begin{aligned} P &= WHF + L \\ &= (120)(18)(.86) + 0 \\ &= 1858 \text{ psf} \end{aligned}$$

2. Determine the pipe wall compressive strength requirement by evaluating the cross sectional area of the pipe wall. First, rearrange the terms in Equation 2.

$$A = \frac{ND_oP}{288 S_c}$$

Before solving this equation an outside diameter of the pipe must be determined. To compute D_o assume that Class 63 pipe will be used. (A small error in assuming D_o will have minimal effect on pipe selection).

$$A = \frac{(2) [(60 \text{ in.} + (2) (2.41))] (1858)}{(288) (1600)}$$

Area Required = 0.523 in.²

Using Tables 3-6 for 60" pipe search for a class of pipe sufficient to provide the required area. 60" Class 63 has an area of 0.552 which is greater than the required area of 0.523. Therefore, Class 63 is chosen to satisfy the wall compressive load.

3. Determine the pipe's constrained wall buckling resistance with Equation 3 by evaluating the required moment of inertia of the pipe wall. If the pipe is above the water table it is not normally required to check for buckling.

Rearrange the terms in Equation 3:

$$I = \frac{(P_{wc})^2 N^2 D_m^3}{(5.65^2) RB' E' E}$$

Where: H = 18 ft.

H = 9 ft.

R = (1 - .33 (9/18)) = 0.835

B' = $\frac{1}{1 + 4e^{(-0.065H)}}$

N = 2

E' = 2000 psi

E = 28250 psi

$D_m = 60 + (2) (0.68) = 61.36 \text{ in.}$

P = WHF+L

Note: Use F 1.0 for this evaluation - prism load

$$= (120)(18)(1.0) + 0 = 2160 \text{ psf (In psi: } 2160/144 = 15 \text{ psi)}$$

$$I = \frac{(15^2) (2^2) (61.36^3)}{(5.65^2) (0.835) (0.446) (2000) (28250)}$$

Required Moment of Inertia = 0.310 in.⁴/in.

Again using Tables 3-6, search the 60" Moment of Inertia column (I) for a Moment of Inertia greater than or equal to 0.310 in⁴/in. A pipe of Class 100 (I = 0.485) is required to satisfy the constrained wall buckling resistance equation.

4. The final design evaluation calculates the average initial pipe deflection. Use Spangler's Iowa Equation (Equation 6):

$$\frac{Y}{D_i} = \frac{P}{144} * \frac{0.1L}{(1.24) (RSC) / D + .061 E'}$$

Where: P = WHF + Live Load (**Note:** Use $F = 1.0$ for this evaluation - prism load)

$$= (120)(18)(1) + 0 = 2160 \text{ psf}$$

RSC = 100 (highest value selected from Steps 1-2)

$$L = 1.0$$

$$D = 60''$$

$$E' = 2000 \text{ psi}$$

Y = Vertical pipe deformation (in.)

$$\frac{Y}{D_i} = \frac{2160}{144} * \frac{(0.1)(1)}{(1.24)(100/60) + .061(2000)}$$

$$\frac{Y}{D} = 1.2\% \text{ Average Deflection}$$

In this example, 60" class 63 was adequate to provide for the required wall crush strength for this particular application. However, 60" Class 100 was required to meet the requirements of the constrained buckling equation. Therefore, the constrained buckling requirements govern the design and Class 100 is required for this application.

Actual safety factors for crush and buckling may be determined, if desired, by using the pipe properties of the required class using the prior formulas and solving for safety factors.

SPECIFICATIONS

SECTION 1 - GENERAL

SECTION 1.1 SCOPE:

1.1.1 This specification covers the requirements of Spirolite® High Density Poly ethylene gravity sewer pipe and fittings in nominal sizes of 18-through 120-inch with integral bell joints, per ASTM F-894.

SECTION 1.2 DEFINITIONS:

Under this standard, the following definitions apply:

1.2.1. Purchaser: The person, firm, corporation or government agency engaging in a contract or agreement to purchase pipe according to this standard.

1.2.2. Inspector: The authorized representative of the purchaser entrusted with the duty of inspecting pipe produced and witnessing tests performed with under these standards.

1.2.3. Inspection: Inspection of the pipe and the tests by the inspector:

1.2.4. Pipe Design: The pipe shall be manufactured by the continuous winding of a special profile onto suitably sized mandrels. It shall be produced to constant internal diameters. The pipe wall profile shall be in accordance with the manufacturer's recommendation.

1.2.5. Joints: The pipe shall be produced with bell and spigot end construction. Joining will be accomplished by rubber gasket, or thermal welding, as determined by the design engineer in accordance with the manufacturer's recommendations.

The integral bell and spigot gasketed joint is designed so that when assembled, the elastometric gasket, contained in a machined groove on the pipe spigot, is compressed radially in the pipe bell to form a positive seal. The joint shall be so designed to avoid displacement of the gasket when installed in accordance with the manufacturer's recommendations.

SECTION 2 - BASIC MATERIALS

SECTION 2.1 BASIC MATERIALS:

2.1.1. Pipe and Fittings: The pipe shall be made of high density, high molecular weight polyethylene pipe material having a minimum cell classification of 335444C, as defined in ASTM D-3350 "Specification for Polyethylene Plastic Pipe and Fittings Materials". Clean rework material generated by the manufacturer's own production may be used so long as the pipe or fittings produced meet all the requirements of this specification.

2.1.2. Gaskets: Rubber gaskets shall comply in all respects with the physical requirements specified in the non-pressure requirements of ASTM Specification F-

477. They shall be molded or produced from an extruded shape approved by the manufacturer and spliced into circular form.

2.1.3. Lubricant: The lubricant used for assembly shall have no detrimental effect on the gasket or on the pipe.

SECTION 3- REQUIREMENTS SECTION 3.1 WORKMANSHIP:

3.1.1. The pipe and fittings shall be homogenous throughout and free from visible cracks, holes, foreign inclusions or other injurious defects. The pipe shall be as uniform as commercially practical in color, opacity, density and other physical properties.

SECTION 3.2 DIMENSIONS:

3.2.1. Pipe Dimensions: The nominal inside diameter of the pipe shall be to the specified pipe size. Standard laying lengths shall be 20 feet $\pm 2"$ for up to 72" I.D., 19' laying lengths $\pm 2"$ for over 72" I.D.

3.2.2. Fitting Dimensions: Fittings such as couplings, wyes, tees, adaptors, etc. for use in laying Spirolite® HOPE gravity sewer pipe shall have laying length dimensions as recommended by the manufacturer.

SECTION 3.3 FLATTENING:

3.3.1. There shall be no evidence of splitting, cracking or breaking when the pipe is tested in accordance with Section 3.4.1.

SECTION 3.4 RING STIFFNESS CONSTANT

3.4.1. Ring Stiffness Constant (RSC) values for the pipe can be directly related to the pipe's class designation. (Nominal RSC of Class 40 pipe = 40, etc.) The minimum RSC is 90% of the nominal when tested in accordance with section 4.3.2.

SECTION 4 - INSPECTION AND TESTING

SECTION 4.1 INSPECTION REQUIREMENTS:

4.1.1. Notification: If inspection is specified by the purchaser, the manufacturer shall notify the purchaser in advance of the date, time and place of testing of the pipe in order that the purchaser may be represented at the test.

4.1.2. Access: The inspector shall have free access to the inspection area of the manufacturer's plant. The manufacturer shall make available to the inspector, without charge, all reasonable facilities for determining whether the pipe meets the requirements of this specification.

4.1.3. Certification: As the basis of the acceptance of the material, the manufacturer will furnish a certificate of conformance to these specifications upon request. When prior agreement is being made in writing between the purchaser and the manufacturer, the manufacturer will furnish other conformance certification in the form of affidavit of conformance, test results, or copies of test reports.

SECTION 4.2 PHYSICAL TEST REQUIREMENTS:

4.2.1. Sampling: The selection of the sample or samples of pipe shall be as agreed upon by the purchaser and the manufacturer. In case of

no prior agreement, any sample selected by the manufacturer shall be deemed adequate.

4.2.1.1. Sample size for flattening test will be one sample per size and class of pipe per project.

4.2.2. Conditioning: Conditioning of samples prior to and during tests shall be as agreed upon by the purchaser and manufacturer. In case of no prior agreement, the conditioning procedure used by the manufacturer shall be deemed adequate.

SECTION 4.3 TEST METHODS:

4.3.1. Flattening: Three specimens of pipe, a minimum of 12 inches long, shall be flattened between parallel plates in a suitable press until the distance between the plates is 40 percent of the outside diameter of the pipe. The rate of loading shall be uniform and such that the compression is completed within 2 to 5 minutes. Remove the load, and examine the specimens for splitting, cracking or breaking.

4.3.2. Pipe Ring Stiffness Constant: The pipe ring stiffness constant shall be determined utilizing procedures similar to those outlined in ASTM D-2412. The stiffness of Spirolite® HOPE Pipe is defined in terms of the load, applied between parallel plates, which causes a 1% reduction of pipe diameter. Test specimens shall be a minimum of two pipe diameters or 4-feet in length, whichever is less.

SECTION 5 - MARKING AND DELIVERY

5.1.1. Each standard and random length of pipe in compliance with this standard shall be clearly marked with the following information.

Pipe Size

Class & Profile Number

Production Code

SECTION 5.2 DELIVERY:

5.2.1. All pipe, couplings and fittings shall, unless otherwise specified, be prepared for standard commercial shipment.

NOTES:

NOTES:

